

SUR-SIZE™ CUT-TO-LENGTH ASSEMBLY

FG-250
FG-400
FG-630

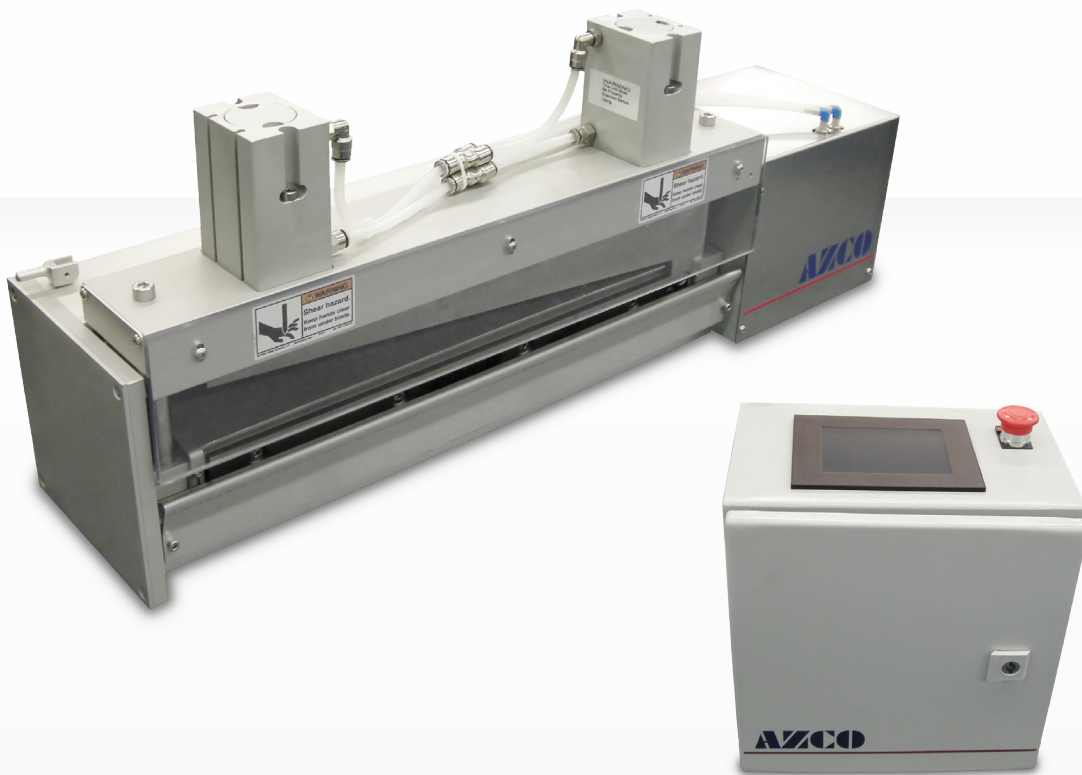

SUR-SIZE™ CUT-TO-LENGTH ASSEMBLY

FG SERIES TECHNICAL SPECIFICATION

Solid Models & Videos Available Online

Simple and easy to use, just enter the length and quantity on the color touchscreen. The unit automatically feeds, cuts, and counts the pieces to meet your requirements. An end-of-cycle signal is provided once the cuts are completed. For an automated one-shot process, this unit will feed and cut the material on demand. Clean cuts are provided by the guillotine knife assembly.

This integrated unit is a convenient package for many users who just want to plug in a power cord and air-line to start cutting their product.

We can support each of these Sur-Size™ units around the world with our remote access. Each unit is built with a USB port which is directly connected to the controls. The unit can be connected to an internet interface utilizing a USB cable, allowing tech support from anywhere in the world.

** DENOTES DIMENSION WITH
SPRING CLAMP OPTION

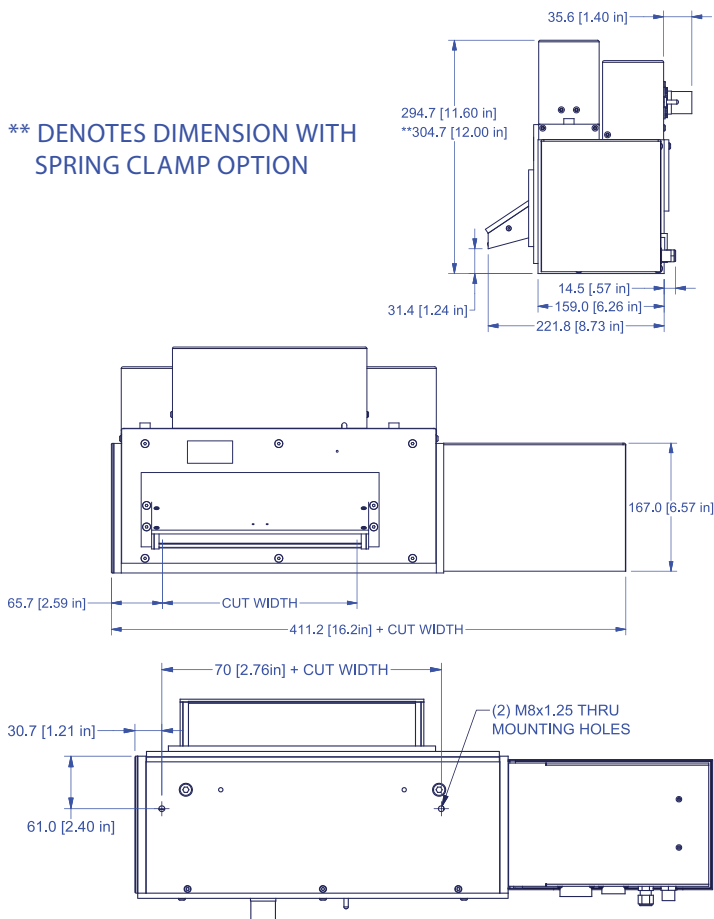

BENEFITS

- Easy to use as a stand-alone unit or as an in-line component
- Easy operator interface with color touchscreen
- Enter lengths in either inches or metric
- Modular knife cartridge
- On demand one-shot cuts
- Reduced scrap
- Eliminates the need for a large inventory of cut product

MATERIALS

- Absorbent Pads
- Film
- Felt
- Foam
- Foil
- Gaskets
- Hose
- Laminates
- Mesh
- Metalized Film
- Non-wovens
- Pads
- Paper
- Personal Care Products
- PTFE
- Rubber
- Shrink Tubing
- Tape
- Test Strips
- Thin Gauge Metal
- Tubing
- Velcro

SPECIFICATIONS

- Minimum length: 0.1 mm/0.005"
- Maximum quantity count: 999,999
- Power requirements: 110 V AC or 220 V AC
- 50-60 Hz
- 30 - 90 psi (2 - 6 bar) compressed air
- Accuracy: +/- 0.38 mm/0.015" or 0.1% of cut length (whichever is larger)

OPTIONS

- Eye registration: a fiber optic sensor locates a registration mark to cycle the unit
- No-product sensor
- Product verification sensor
- Pneumatic preloaded idler roller
- High accuracy drive up to +/- 0.05 mm/0.002"
- One-shot input and feedback output
- Infeed roll unwind
- Outfeed conveyor
- I/O expansion card: 24 inputs / 12 outputs
- Servo drive package
- Slitter attachment
- Steel drive roller
- Static control
- Specials up to 1676 mm / 66" wide
- All electric



WARNING:

EQUIPMENT MUST BE GUARDED IN ACCORDANCE WITH ALL FEDERAL, STATE, AND LOCAL REQUIREMENTS



visit us online!



FOR ALL YOUR FEEDING AND CUTTING NEEDS

26 Just Road, Fairfield, NJ, 07004 | 973-439-1428 | azcocorp.com