

AZCO SUR-PAK™ DESICCANT DISPENSER

MODEL: VIP-100



AZCO SUR-PAK™ DESICCANT DISPENSER

VIP-100 TECHNICAL SPECIFICATION

Solid Models & Videos Available Online

If you are looking to dispense desiccants, oxygen absorbers, food packs, or promotional items, the VIP-100 is the ideal solution.

Setting up the VIP-100 is easy with the color touchscreen. Product changes can be made without the use of tools in just 90 seconds, with knife replacement done in just 60 seconds. Equipped with feed tracking technology, this unit can process continuous strips of pouches at up to 300 cycles per minute. Software is included that monitors the position of the seals to detect any errors, resulting in accurate and consistent dispensing of products. The cantilever design offers complete access to the process, and the open exit chute virtually eliminates any complicated jamming situations. In the event of any technical difficulties, remote access allows us to provide immediate online diagnostics and technical support from anywhere in the world.

BENEFITS

- Color touch screen for easy operator setup
- Cantilever design offers complete access and a full view of feeding process
- Dual drive belting controlled from the touch screen
- Knife cartridge replacement in just 60 seconds
- Tool-less product change in just 90 seconds
- Open exit chute virtually jam free
- 300 cycles per minute
- Servo drive offers high speed dispensing
- PLC controls with a USB port
- Automatic motorized adjusting stand for fast setup

SPECIFICATIONS

- Power requirements: 110 VAC or 220 VAC, 5 amps
- 30 – 90 psi (2 - 6 bars) compressed air

OPTIONS

- Take-away conveyors provide extended product drops
- Escapements and timing screws
- Allen Bradley controls along with any other standard PLC controls

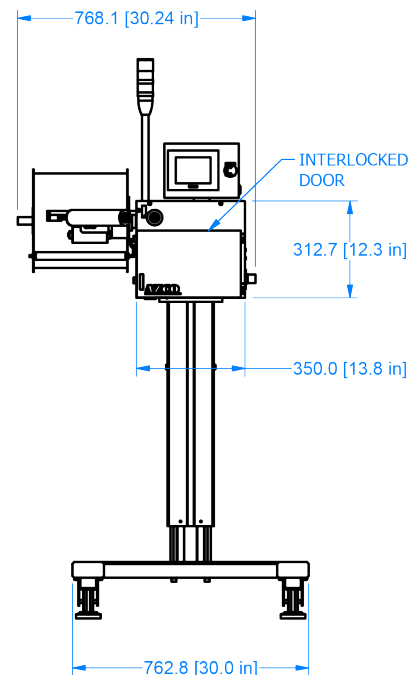
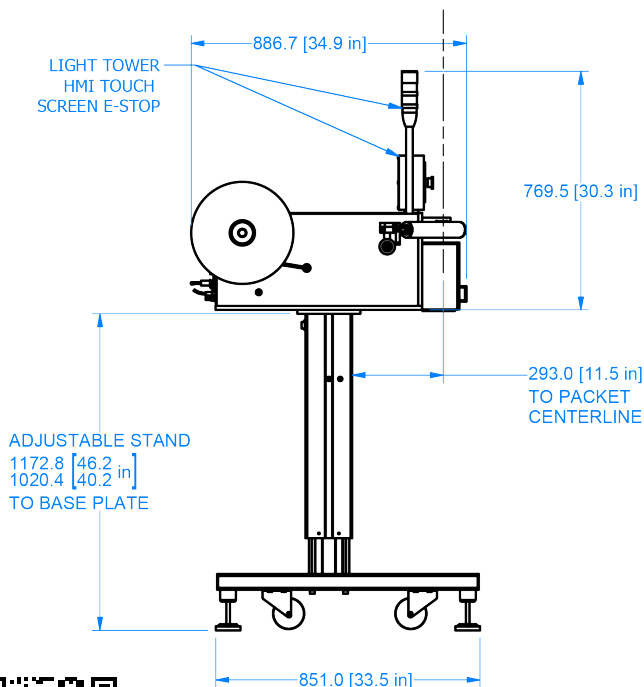

WARNING:

EQUIPMENT MUST BE GUARDED IN ACCORDANCE WITH ALL FEDERAL, STATE, AND LOCAL REQUIREMENTS.



CUSTOM FEEDING & CUTTING SOLUTIONS

26 Just Road, Fairfield, NJ 07004 | 973-439-1428 | azcocorp.com

